

Monitoring Peptide Synthesis

Controlling Solid-Phase Peptide Synthesis in Real-time

Solid-Phase Peptide Synthesis (SPPS) is a widely used method for manufacturing of peptides in a stepwise process on a solid support. It holds great importance in the field of peptide chemistry due to its efficiency, versatility, and ability to produce peptides of high purity and yield. SPPS utilizes a solid support, typically a resin, which facilitates easy purification of the peptide product through filtration or centrifugation. This method enables the synthesis of peptides with complex sequences, thereby expanding the scope of peptide-based research and drug discovery. The precise control and manipulation of peptide sequence and structure afforded by SPPS have revolutionized various scientific disciplines, such as biochemistry, pharmacology, and immunology, leading to the development of new therapeutic agents and research tools.

Monitoring solid-phase peptide synthesis is crucial to ensure reaction progress, optimize reaction conditions, and maintain the quality and integrity of the synthesized peptide product. Recently papers were published showing that Refractive Index measurement is a process analytical tool (PAT) suitable for real-time monitoring SPPS. The refractive index (RI) of a liquid provides key information about its physical properties and the composition of any solution.

In SPPS protected amino acid derivatives are successively added to a growing peptide chain that is immobilized on a solid phase. After adding the protected amino acid to the solid phase, it is deprotected and unreacted groups and side products are removed with washing steps. Afterwards the process is repeated to add further amino acids to the chain. Previously the only chance to monitor these processes was to take a sample and to carry out offline tests like ninhydrin/chloranil test, determination of UV absorption and high-

performance liquid chromatography analysis. To perform these tests the production was sometimes interrupted for several hours.

Studies have proven that all these steps can be monitored in real-time by measuring the refractive index. Due to the fact that the growing peptide chain is anchored to a solid support that is suspended in a solvent, a flow through refractive index measurement is possible. When the incoming protected amino acid and the coupling reagents are added to the solution a reaction takes place where mass is transferred from solution to solid support. In contrast, mass is transferred from solid support to solution when the protecting group is released from the added amino acid. In every washing step, the solution moreover shows a loss of mass. As the refractive index varies in the function of the amount of mass dissolved in the liquid this tool can easily be used to monitor the SPPS in real-time.

Monitoring the solid phase peptide synthesis offers several advantages, including the ability to assess reaction progress, optimize reaction conditions, and ensure the quality and integrity of the synthesized peptide product. By monitoring the synthesis, researchers can detect any issues or deviations early on, allowing for prompt troubleshooting and adjustment of reaction parameters if necessary. This helps in minimizing the risk of incomplete or inefficient peptide synthesis, thus maximizing the yield and purity of the final product. Additionally, monitoring allows for real-time feedback on reaction kinetics, enabling researchers to optimize reaction times and conditions for improved efficiency and reproducibility. Overall, monitoring solid phase peptide synthesis plays a vital role in ensuring the success and reliability of peptide synthesis processes.

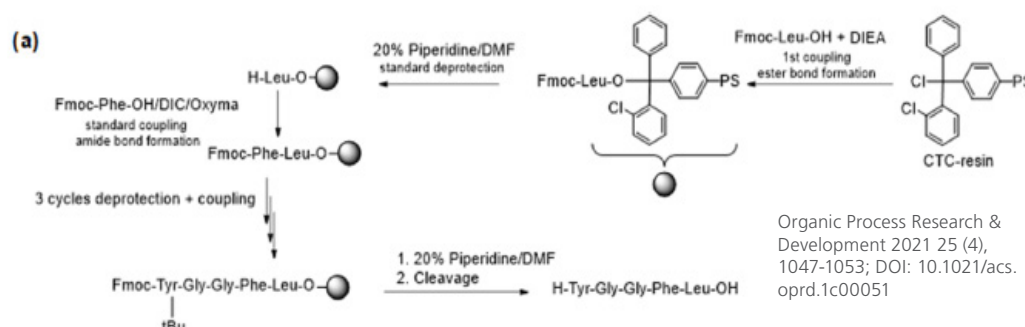

Solution from SCHMIDT + HAENSCH

Solid-phase peptide synthesis can be carried out in smaller laboratories or larger production scales. Both processes can be monitored using SCHMIDT + HAENSCH refractometer.

Smaller laboratory scale:

To monitor the SPPS in small laboratory scales we recommend to use our VariRef laboratory refractometer. Together with a flow through sample compartment door and a membrane pump an at-line monitoring of small scale processes up to several liters is possible.

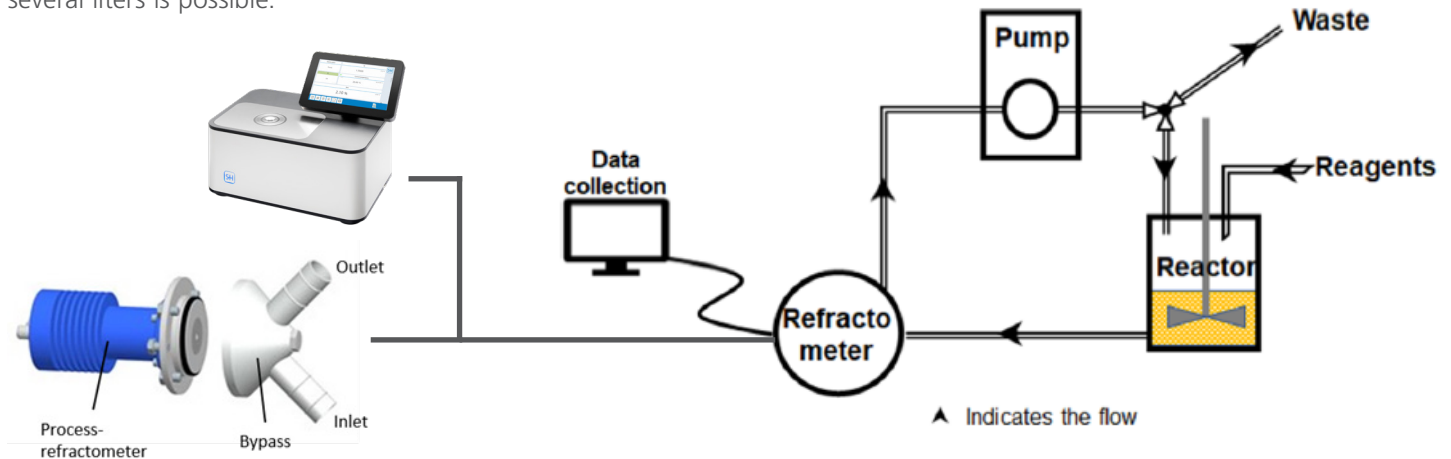

Product packages

Product

ID-N°

Product packages	Product	ID-N°
Small Scale	VariRef B	32111
	Display	16700
	Flow through compartment door	16350 + 16443
	Membrane pump	17670
Large Scale (Bypass)	Process Refractometer	15510
	Sealing	17927
	Bypass connection and hoses	14413
Large Scale (in-line)	Process Refractometer	15510
	Sealing	17927
	Process connection	on request

Benefits

- Cost and time savings
- Accurate, fast and precise measurement
- Product quality securing

Typical Applications

- Peptide/Protein synthesis
- Oligonucleotide synthesis
- Pharmaceutical purification
- Cosmetics



**Scan QR code or
click here to get
a quote!**

SCHMIDT + HAENSCH GmbH & Co.

Waldstraße 80-81, 13403 Berlin, Germany
Tel: + 49 (0 30) 417072-0, Fax: + 49 (0 30) 417072-99
sales@schmidt-haensch.de, www.schmidt-haensch.com